



ERF3000-v2, LTE Cat. M1, Cat.NB1, EGPRS & GNSS Arduino shield





ERF3000-v2, LTE Cat. M1, Cat.NB1, EGPRS & GNSS Arduino shield

Document Information

Title	ERF3000-v2
Subtitle	LTE Cat. M1, Cat. NB1, EGPRS & GNSS Arduino Shield
Document type	Preliminary Datasheet
Document number	1
Revision and date	R1 12-06-2019

Product status

In production

this document applies to the following products:

Name	Type number	version	Product status
ERF3000	ERF3000	1.5	EOL
ERF3000-v2	ERF3000	1.0	In production



ERF3000-v2, LTE Cat. M1, Cat.NB1, EGPRS & GNSS Arduino shield

Contents

1 Functional description	4
1.1 Product overview	4
1.2 Product features	4
2 Pin Assignment	6
2.1 Arduino headers	6
2.2 UART header	7
2.3 GPIO header	7
3 Interfaces	8
3.1 Power	8
3.1.1 Power headers	8
3.2 Antennas	9
3.2.1 GNSS_ANT	9
3.2.2 GSM_ANT (ERF4061 GSM antenna)	9
3.3 Status LED's	9
3.4 SIM interface	10
3.5 UART interface	11
3.6 PCM and I2C interface	11
3.7 ADC interface	12
3.8 GPIO	12
4 Electrical specification	13
5 Mechanical specifications	13
6 Product handling	14
7 Related documents	14
8 About easyRF	14
9 Ordering information	14
10 Technical support	14



ERF3000-v2, LTE Cat. M1, Cat.NB1, EGPRS & GNSS Arduino shield

1 Functional description

1.1 Product overview

The ERF3000-v2 Arduino shield is a series of LTE Cat.M1/Cat.NB1/EGPRS module offering a maximum data rate of 375kbps downlink and uplink. It features ultra-low power consumption, and provides pin-to-pin compatibility with an Arduino UNO.

The Quectel BG96 module on the Arduino shield can be replaced with the Quectel LTE module EG91/EG95, Cat.NB1 (NB-IoT) module BC95-G, UMTS/HSPA module UG95/UG96 and GSM/GPRS module M95.

A rich set of Internet protocols, industry-standard interfaces (USB/UART/I2C/Status Indicator) and abundant functionalities (USB drivers for Windows XP, Windows Vista, Windows 7/8/8.1/10, Linux and Android) extend the applicability of the module to a wide range of M2M applications such as wireless POS, smart metering, tracking, etc.

The ERF3000-v2 combines the Power of the BG96 with an easy to use Arduino platform and allows for rapid testing and development.

1.2 Product features

General features			
Frequency band	BG96-G	Cat-M1/ NB1	LTE FDD: B1/B2/B3/B4/B5/B8/B12/B13/B18/B19/B20/B26/B28 LTE TDD: B39 (for CAT-M1 Only)
		EGPRS	850/900/1800/1900MHz
LTE version		3GPP E-UTRA release 13	
GNSS		GPS, GLONASS, BeiDou/Compass, Galileo, ZSS	
Supply voltage range (BG96)		3.3V~4.3V, 3.8V typ.	
Operation temperature		-40°C~+85°C	
PCB dimensions		57.2 x 84.2 mm (± 0.1)	
Weight		Approx. 30 g	
Control via AT commands		Through Arduino "Software Serial" interface , of through the USB interface on the shield	

Specifications		
SMS		Point to point MO and MT SMS cell broadcast Text and PDU mode
Data	Cat M1	Max. 375Kbps (DL), Max. 375Kbps (UL)
	Cat NB1	Max. 32Kbps (DL), Max. 70Kbps (UL)
	EDGE	Max. 296Kbps (DL), Max. 236.8Kbps (UL)
	GPRS	Max. 107Kbps (DL), Max. 85.6Kbps (UL)
Protocols		PPP/TCP/UDP/SSL/TLS/FTP/HTTP(S)/NITZ/PING/MQTT



ERF3000-v2, LTE Cat. M1, Cat.NB1, EGPRS & GNSS Arduino shield

Interfaces	
USB	2.0 High speed up to 480Mbps
UART	3x
PCM	1x
ADC (15 bits)	2x
GPIO	2x (I2C and UART3 can be re-configured as extra 4 GPIOs)
USIM	1 x (1.8V/3.0V)
NETLIGHT	Network Status Indication
STATUS	Power ON/OFF Status Indication

Electrical characteristics (BG96 module)			
Output power			Max. Power: 23dBm
Consumption	LTE Cat M1 (typical)	Power saving mode	10uA
		Idle State	16mA @DRX=1.28s 15mA @e-I-DRX=20.48s
		Sleep State	1.7mA @DRX=1.28s 1.1mA @e-I-DRX=20.48s
		LTE Connected Mode (Avg.)	124mA @0dBm 130mA @10dBm 190mA @23dBm
	LTE Cat NB1 (typical)	Power saving mode	10uA
		Idle State	16mA @DRX=1.28s 15mA @e-I-DRX=20.48s
		Sleep State	2.3mA @DRX=1.28s 1.7mA @e-I-DRX=20.48s
		LTE Connected Mode (Avg.)	65mA @0dBm 66mA @10dBm 78mA @23dBm
Sensitivity			-107dBm @Cat M1, 1.4MHz Bandwidth, CE Mode A -113dBm @Cat NB1, CE Level 0



ERF3000-v2, LTE Cat. M1, Cat.NB1, EGPRS & GNSS Arduino shield

2 Pin Assignment

2.1 Arduino headers

The ERF3000-v2 shield is designed to be an Arduino shield. Below, the interface to the Arduino board can be found.

I/O Parameter Definition

Type	Description
IO	Bidirectional
DI	Digital input
DO	Digital output
PI	Power input
PO	Power output
AI	Analog input
AO	Analog output
OD	Open drain

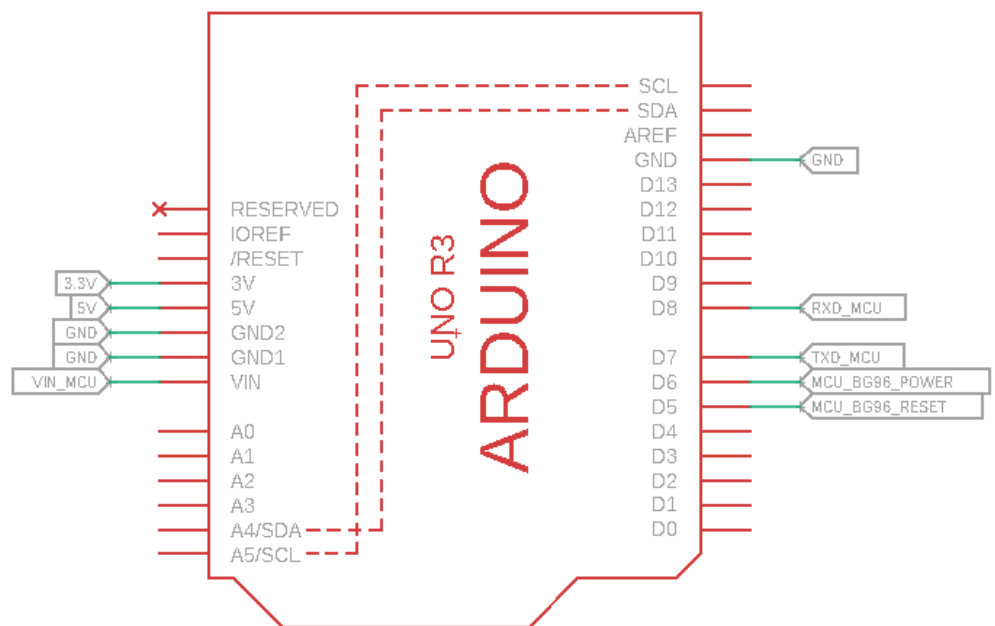

Header	Name	Power domain	I/O	Description
Arduino header	3.3V	3.3V	PI	3.3V input level shifter reference voltage
Arduino header	5V	5V	PI	5V input level shifter reference voltage
Arduino header	GND	-	-	Ground
Arduino header	GND	-	-	Ground
Arduino header	VIN_MCU	5V to 12V	PI	External input to power shield (recommended minimal 5V, 2A) when used as power supply
Arduino header	GND	-	-	Ground
Arduino header	RXD_MCU	V_level_shifter	DI	Receive data
Arduino header	TXD_MCU	V_level_shifter	DO	Transmit data
Arduino header	MCU_BG96_POWER	3.3V	DI	Turn module On/Off (active high)
Arduino header	MCU_BG96_RESET	3.3V	DI	Reset module (active high)



ERF3000-v2, LTE Cat. M1, Cat.NB1, EGPRS & GNSS Arduino shield

2.2 UART header

The UART header is connected to all UART1 interface related I/O's from the Quectel module on the shield. All these signals are routed through the level shifter. Depending on the position of the level shift header, the voltage of the signals will be 3.3V or 5.0V.

Header	Pin No.	Name	Power domain	I/O	Description
UART	1	RI	V_level_shifter	DO	Ring indicator
UART	2	DCD	V_level_shifter	DO	Data carrier detection
UART	3	RTS	V_level_shifter	DI	Request to send
UART	4	CTS	V_level_shifter	DO	Clear to send
UART	5	TXD	V_level_shifter	DO	Transmit data
UART	6	RXD	V_level_shifter	DI	Receive data
UART	7	DTR	V_level_shifter	DI	Data terminal ready (Sleep mode control)
UART	8	GND	GND	-	Ground

2.3 GPIO header

The GPIO header is connected to all the GPIO related I/O's from the Quectel module on the shield.

Header	Pin No.	Name	Power domain	I/O	Description
GPIO	1	PSM_IND	1.8V	DO	Power saving mode indicator
GPIO	2	ADC1	0.3V to 1.8V	AI	Analog to digital converter
GPIO	3	PCM_CLK	1.8V	DO	PCM clock output
GPIO	4	PCM_SYNC	1.8V	DO	PCM frame synchronization output
GPIO	5	PCM_DIN	1.8V	DI	PCM data input
GPIO	6	PCM_DOUT	1.8V	DO	PCM data output
GPIO	7	GPIO	1.8V	IO	General purpose input / output
GPIO	8	W_DISABLE#	1.8V	DI	Airplane mode control
GPIO	9	AP_READY	1.8V	DI	Application processor sleep state detection
GPIO	10	DBG_RXD	1.8V	DI	Receive data
GPIO	11	DBG_TXD	1.8V	DO	Transmit data
GPIO	12	ADC0	0.3V to 1.8V	AI	Analog to digital converter
GPIO	13	GPIO	1.8V	IO	General purpose input / output
GPIO	14	Reserved	-	-	Keep this pin open
GPIO	15	UART3_RXD	1.8V	DI	Receive data
GPIO	16	UART3_TXD	1.8V	DO	Transmit data
GPIO	17	I2C_SDA	1.8V	OD	I2C serial data (external pull-up resistor is required)
GPIO	18	I2C_SCL	1.8V	OD	I2C serial clock (external pull-up resistor is required)



ERF3000-v2, LTE Cat. M1, Cat.NB1, EGPRS & GNSS Arduino shield

3 Interfaces

3.1 Power

The ERF3000-v2 shield must be supplied through the shield barrel jack (5V to 12V DC) Voltage must be stable during module operation, taking into account that the current drawn from VCC pins may vary significantly based on the power consumption profile of the IoT system.

The power adapter supplied with the shield is CUI part SW110-5-E-P5. This is a 5V, 2A power adapter with a maximum power of 10W.

Alternatively the shield can be powered by an external source through the VIN pin*.

*Please see chapter [2.1 Arduino headers](#) for more details.



When powering the shield through the VIN pin, please keep in mind the voltage must be stable and can't exceed 12V. Also please be cautious when an Arduino Uno is used to supply the shield. The Arduino UNO can only supply 500mA max. the shield can draw up to 2A, and in this process the Arduino UNO can be damaged.

3.1.1 Power headers

The Shield has 3 important power headers, the VIN header, the level shift header and the current measurement header. These are marked with a red box on the following picture:

The VIN header must be closed when the shield is supplied through the VIN pin on the Arduino header.

The level shift header must be placed on either 3.3V or 5V, this depends on the microprocessor board used in combination with the shield.

At last an additional header can be soldered on the shield to measure the consumed current by the Quectel module*.

*For more information regarding the current measurement, please see the [ERF3000-v2 User guide v1.0.pdf](#).

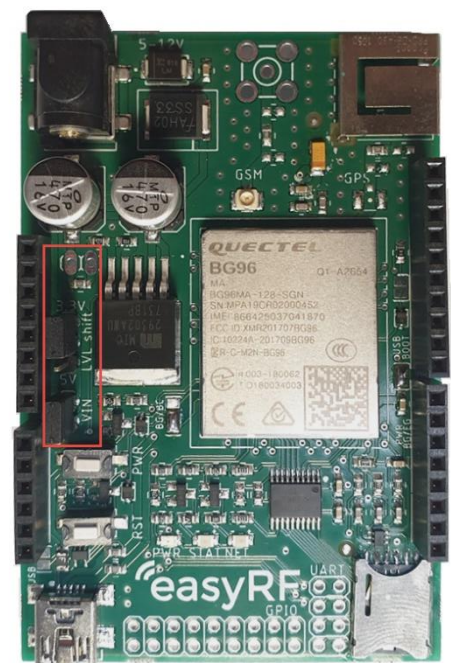



ERF3000-v2, LTE Cat. M1, Cat.NB1, EGPRS & GNSS Arduino shield

3.2 Antennas

The ERF3000-v2 uses 2 antennas, 1 GPS antenna and 1 GSM antenna.

The GPS antenna is integrated on the PCB and the GSM antenna needs to be connected to the U.fl connector.

It is important to note that the antennas can't be too close to one another, because they will cause interference. This causes problems when using the GPS function of the shield.

3.2.1 GNSS_ANT

The ProAnt 430 antenna is an onboard SMD, GPS/GLONASS antenna.

The center frequency is around 1575 MHz.

3.2.2 GSM_ANT (ERF4061 GSM antenna)

The ERF4061 antenna is a GSM PCB antenna. The antenna can be used in the frequency band of 800~900 / 1500 / 2100~2300 MHz. The antenna can be used for applications, GSM, M2M, NB-IoT and CAT-M.

For more information see [ERF4061 datasheet](#)

3.3 Status LED's

The shield also has 3 LED's to give an indication of the status of the shield.



Led	Color	State	Description
PWR	Green	Always on	Shield is powered
		Always off	Shield is not powered
STAT	Red	0.2s on/1.8 off	Searching for network
		1.8s on/0.2s off	Connected to network
		0.125s on/0.125s off	Data transfer is ongoing with a network
NET	Yellow	Always on	Registered on network
		Always off	Not registered on network



ERF3000-v2, LTE Cat. M1, Cat.NB1, EGPRS & GNSS Arduino shield

3.4 SIM interface

To register and connect to a network, a SIM card needs to be inserted and activated.

When an activated SIM is inserted, the functionality of the SIM card should be checked with AT+CIMI and AT+QCCID.* The Attend model number of the SIM card socket is 115U-A000.

*For more information see: [Quectel BG96 AT Commands Manual.pdf](#)

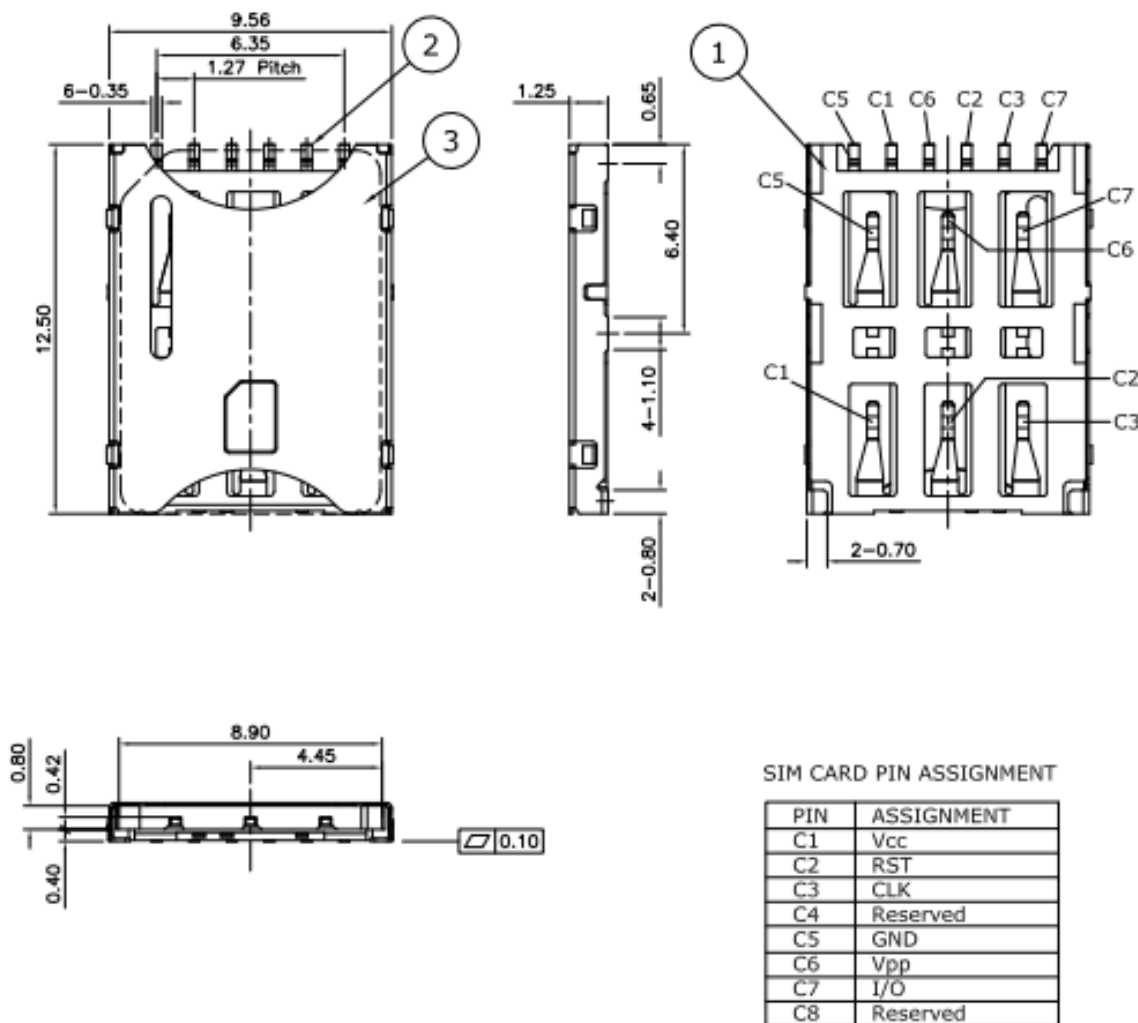



ERF3000-v2, LTE Cat. M1, Cat.NB1, EGPRS & GNSS Arduino shield

3.5 UART interface

The ERF3000-v2 shield provides 3 UART ports:

Interface	Supported Baud rates	Description
UART1	9600, 19200, 38400, 57600, 115200, 230400, 460800 and 921600bps (115200 is the default value)	The main UART port, this is used for data transmission and AT command communication
UART2	115200bps	The debug UART port, used for debugging and log output
UART3	115200bps	The GNSS UART port, used for outputting GNSS and NMEA sentences

The UART1 interface can be found on the UART header. All signals are routed through a level shifter. The voltage of the signals can either be 3.3V or 5.0V. this is dependent on the position of the level shift header.

Both UART2 and 3 can be found on the GPIO header, and are both in the 1.8V domain.

Please see chapter [2.2 UART header](#) and [2.3 GPIO header](#) for more details regarding the exact location of the UART signals.

3.6 PCM and I2C interface

The BG96 provides one Pulse Code Modulation (PCM) digital interface and one I2C interface. These can for example be used in combination with an audio codec.

In below image an example provided by Quectel is shown of how an audio codec can be implemented.

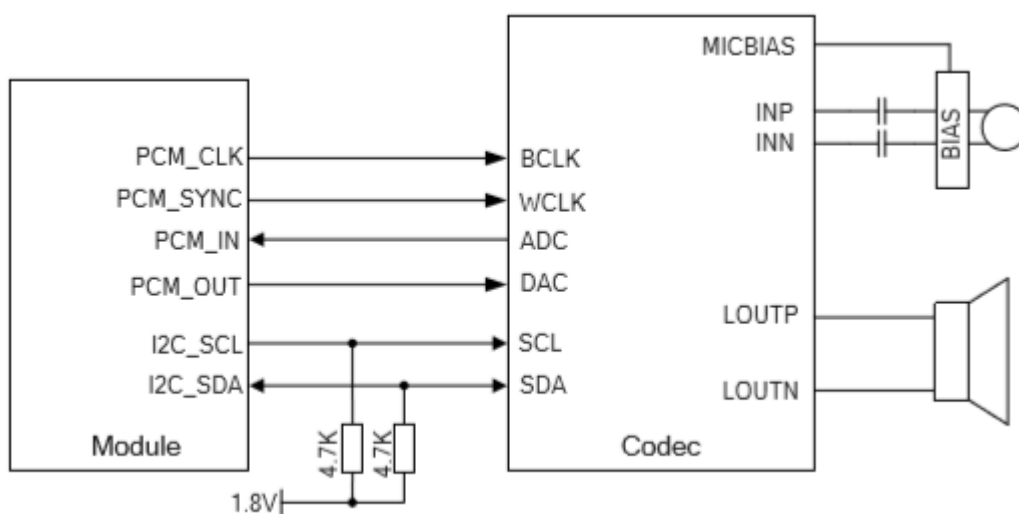



ERF3000-v2, LTE Cat. M1, Cat.NB1, EGPRS & GNSS Arduino shield

3.7 ADC interface

The BG96 provides two analog-to-digital (ADC) interfaces. The voltage on these interfaces can be read with the AT+QADC command. For ADC0 use AT+QADC=0 and for ADC1 use AT+QADC=1.

Parameter	Min.	Max.	Unit
ADC0 Voltage Range	0.3	1.8	V
ADC1 Voltage Range	0.3	1.8	V
ADC Resolution	-	15	bits

3.8 GPIO

The module also provides 2 GPIO interfaces. these can be controlled with the AT+QFWD="GPIO" command.

AT+QFWD="gpio",<mode>,<pin>[,<dir>,<pull>,<drv>]/[<val>][,<save>]]



ERF3000-v2, LTE Cat. M1, Cat.NB1, EGPRS & GNSS Arduino shield

4 Electrical specification



A power supply with 5 ~ 12V DC output with a minimum of 2A is needed to power the shield. 12V is the absolute max, do not exceed this.

The power must be supplied to the DC jack located on the shield or to the Arduino DC jack*.

*Please see chapter [3.1 Power](#) for the power options.

5 Mechanical specifications

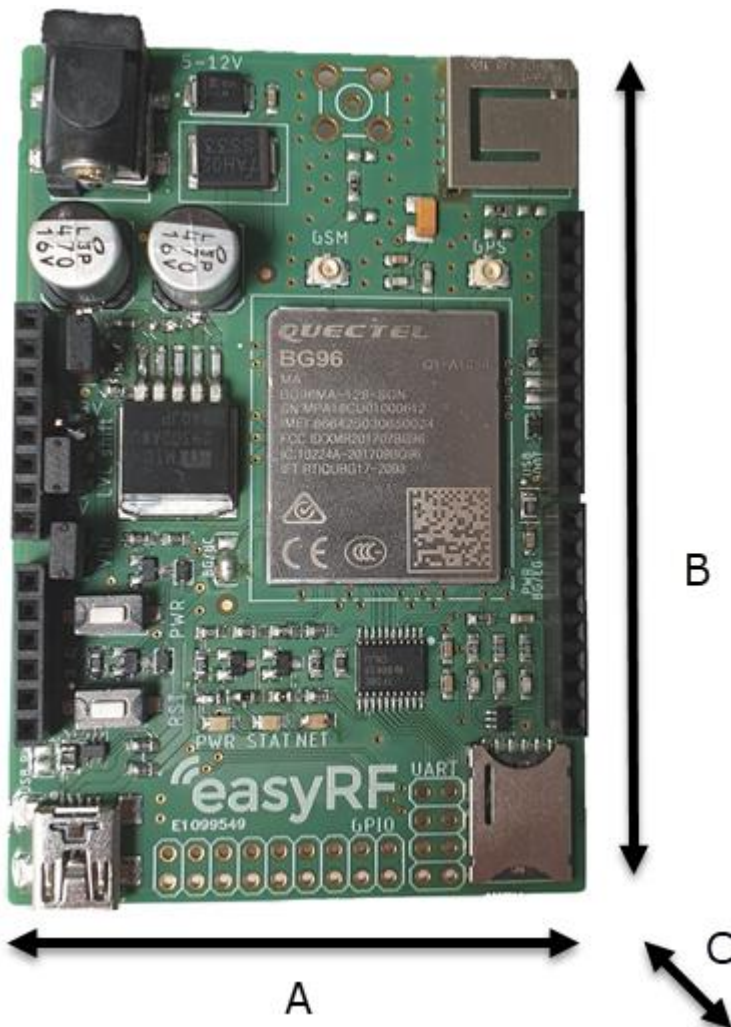

Parameter	Dimension
A Width	54 ± 2 mm
B Length	80 ± 2 mm
C Height	21 ± 2 mm



ERF3000-v2, LTE Cat. M1, Cat.NB1, EGPRS & GNSS Arduino shield

6 Product handling

Handle with ESD safety care.



7 Related documents

Document	Distributor
ERF4061 Datasheet.pdf	easyRF
Quectel_BG96_AT_Commands_Manual_V2.3.pdf	Quectel
ERF3000-v2_User_Guide_V1.0.pdf	easyRF

About easyRF

easyRF is supplier and manufacturer of wireless communication solutions with an easy-to-use approach, targeting different applications and markets. The products are standard off-the-shelf products, but customization of the products is possible.

easyRF is successful in the a wide range of markets, such as: industrial, agriculture, security, building automation.

Ordering information

Please check www.easyRF.eu or www.TOP-electronics.com for more information.

The shield is available as the following packages:

Package	ERF3000	ERF3001	ERF3000-v2
Includes	- BG96 Arduino shield - GSM antenna - Power adapter	- BC95-B8/B20 Arduino shield - GSM antenna	- BG96 Arduino shield - GSM antenna - Power adapter

Technical support

For all product related questions please contact us via info@easyRF.eu

Or through our distributor, TOP-electronics via support@top-electronics.com